

	TYPE	No.
1	HTH 10-140-40-1-310	1200
2	HTH 10-190-60-1-310S	1000
3	HTH 10-220-70-2-310S	2000
4	HTH 12-400-100-4-310S	400
5	HA 50*100*10 310S پایه انکر	200

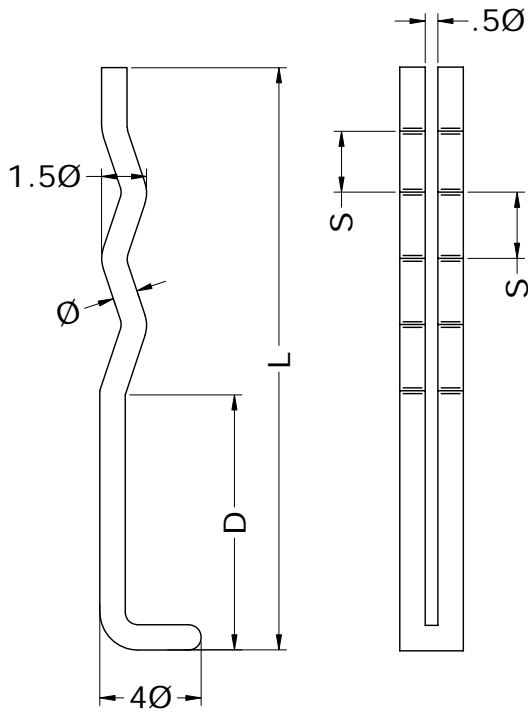

for construction

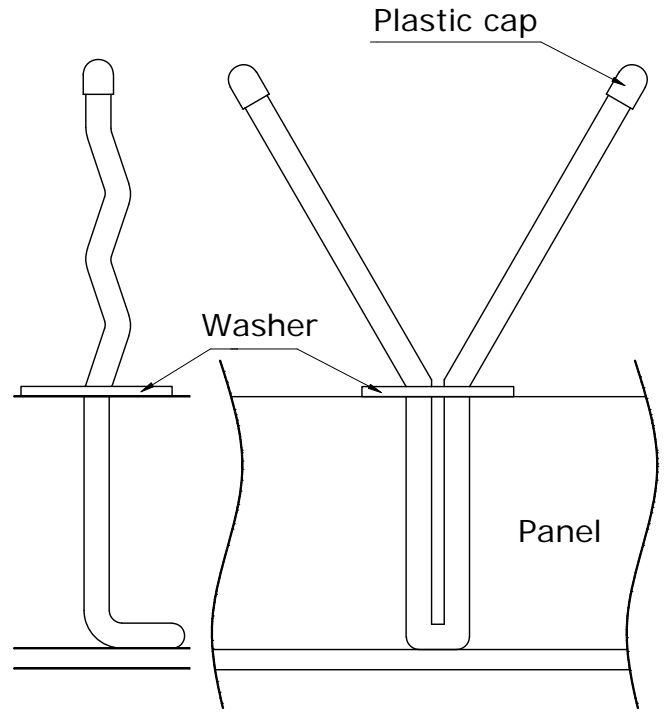

after welding to casing

Name format: HTH.Ø-L-D-N-*K

N: Number of corrugations

S: 20mm (Ø=6mm)

S: 25mm (Ø=8mm)

S: 30mm (Ø=10mm)

Washer specification according to DIN9021:

for Ø6mm : Ø13/Ø40x3mm

for Ø8mm : Ø17/Ø50x3mm

for Ø10mm : Ø21/Ø60x4mm

*: 304 (1.4301), 309 (1.4828), 310 (1.4842), 314 (1.4841)

inner diameter of Plastic caps must be equal to anchors' diameter.

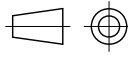
CLIENT: JOVEIN CEMENT Co.			SUPPLIER: IDEH PARDAZAN SANAT 		
PROJECT TITLE: JOVEIN CEMENT PLANT		 CAD	Pos.: ---	Material: ---	Weight (Kg): ---
			QTY: ---	STD: ---	Unit: mm
	DATE:	SIGN:	DRAWING TITLE: Refractory Lining Metallic anchor-type HTH		
DESIGNED BY:	87/1/5	H.Hashemi Javan			
DRAWN BY:	87/1/5	M.Azadmanesh			
CHECKED BY:	87/2/1	H.Hashemi Javan			
APPROVED BY:	87/2/1	H.Hashemi Javan			
CAD FILE NO.: 4-000-RF-000-130-00-02			DRAWING NO.: 4.000.RF.000.130.00.02		
			SIZE: A4	SCALE: 1:3	
			SHEET NO.: 1/1		
			REV.: 0		

RHA 50x115x10

HOLDER TYPE

WIDTH B = 50 MM

LENGTH L: MIN.= 60 MM

THICKNESS S = 6 MM, 8 MM, 10 MM

MATERIAL: ST37, 1.4301, 1.4828, 1.4841

AISI: 304, 309, 314

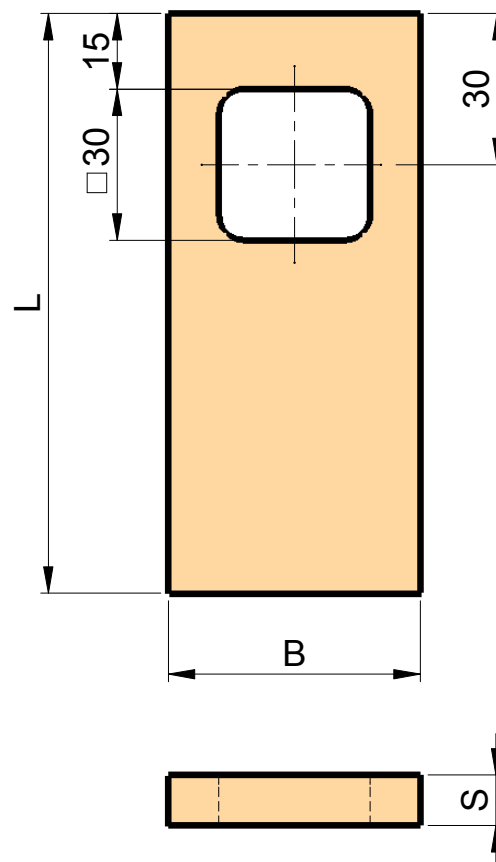

02	Bemaßung	08.11.2012	Bu
01	Bemaßung	07.02.2011	EI
Index	Revision	Date	Name
drawn:		03.05.2010	Ger